

C & U

CREATIVE
& UNIQUE



EMS Test System **MR2350**

Compact and easy-to-use EMS total test system
– Precompliance –

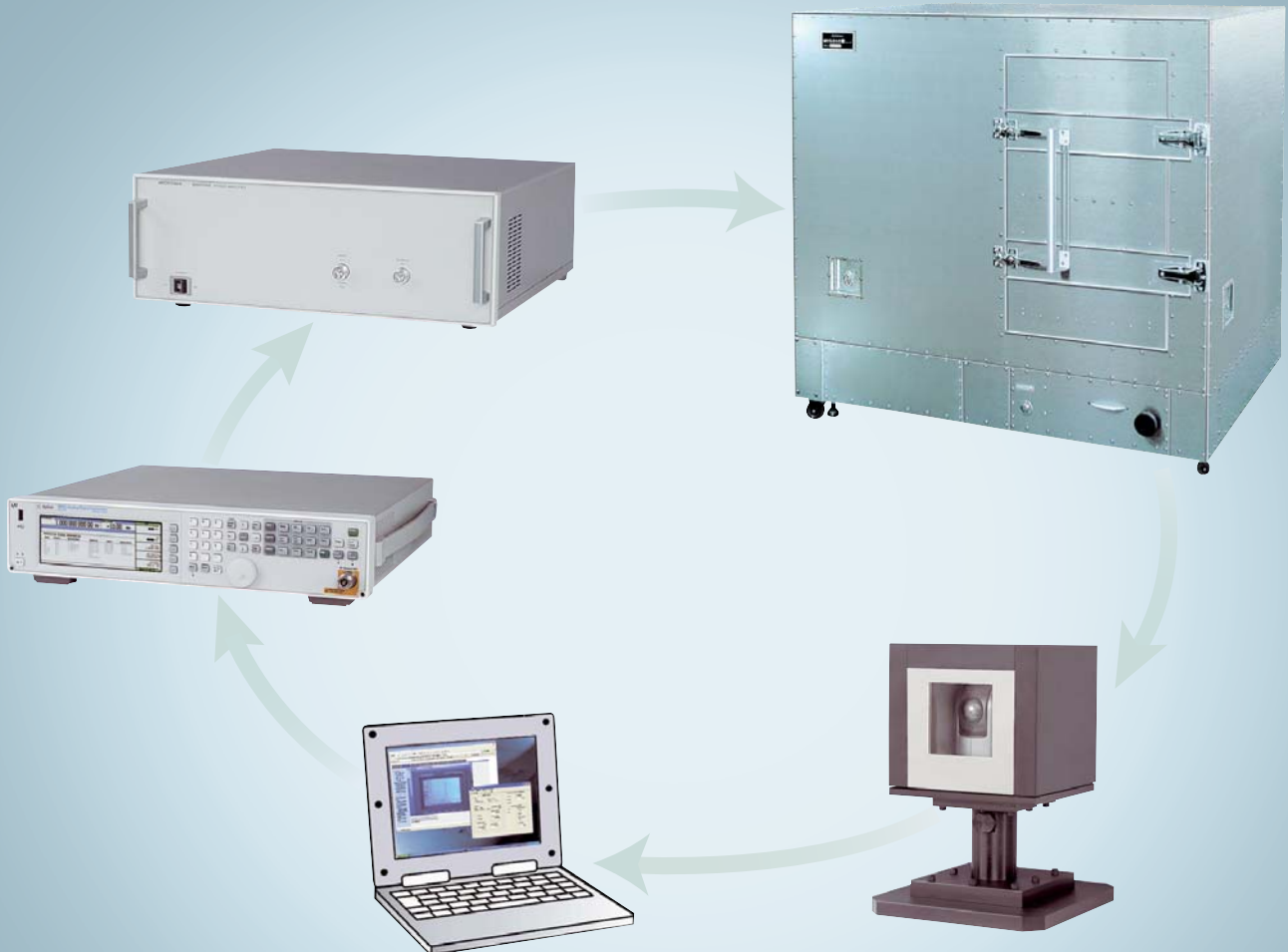

MICRONIX

Outline of MR2350

※ PC is not included in the system price.

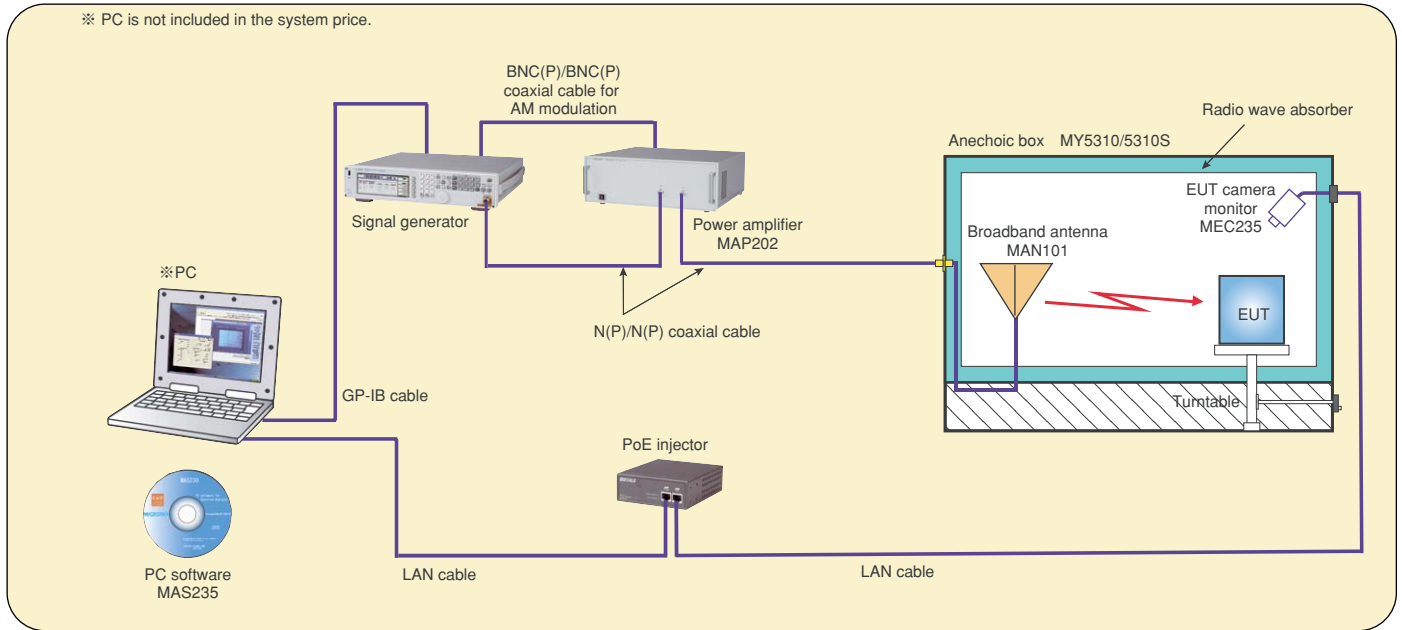

About EMS test

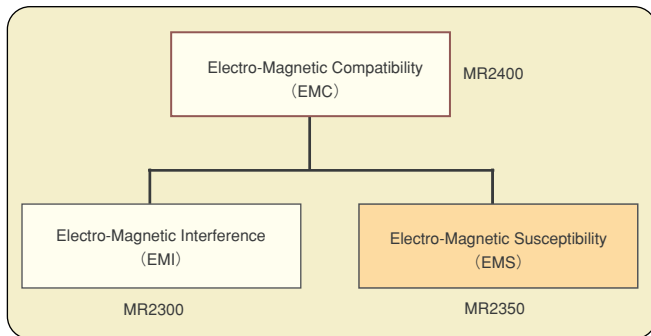

EMC test consists of EMI and EMS tests. As for EMI test, it is evaluated whether the radiated emission or the conducted emission discharged from EUT (Equipment Under Test) exceeds the limit value set beforehand. This limit value is used to guarantee that the EUT operation doesn't give a remarkable disturbance to operation of other equipment and wireless communication. The emission test described above can be done by the EMI test system **MR2300**.

On the other hand, it is evaluated in the EMS test whether the EUT causes the malfunction by a peripheral electromagnetic wave. This radiation immunity test can be done with the precompliance EMS test system **MR2350** described in this catalogue. The malfunction of the EUT can be observed on the PC screen through the EUT camera monitor put in the anechoic box. Of course, the EUT should be an equipment whose malfunction can be visually judged such as an equipment with LED or LCD.

EMI+EMS test system MR2400

The system combining the EMI test system MR2300 and the EMS test system MR2350 is the EMC test system MR2400. The PC software for MR2400 is MAS240.

The price of MR2400 becomes much lower than purchasing MR2300 and MR2350 separately because the anechoic box MY5310/5310S and the broadband antenna MAN101 are common to two systems.

Features of MR2350

1 Electric field strength of 1, 3, 10V/m

The electric field strength of 1, 3, 10V/m and moreover optionally 1 to 10V/m can be generated.

2 Multifunction detection by EUT camera monitor

The malfunction of the EUT by the electromagnetic radiation can be observed by a camera put in the anechoic box. The image is displayed on the PC screen.

3 Compact and broadband antenna by our own development

The antenna, whose dimensions are as small as 578(W) × 401(H) × 250(D)mm and whose bandwidth is as broad as 30MHz to 3GHz, was developed by MICRONIX itself.

4 EMI+EMS test by MR2400

MR2400 combining the EMI test system MR2300 and the EMS test system MR2350 makes the EMC (EMI+EMS) test possible.

5 Whole system controlled with one PC

One PC controls all of applications such as the EMI test, the EMS test, the EUT camera monitor and the electric turntable (option).

6 Electric turntable (factory option)

This option is an electric turntable of 220mm in diameter and 15kg in load. And this is controlled by the PC.

※ This can be applied to the EMI test system MR2300 as well. MAS20T and MAS240T are lined up as PC software.

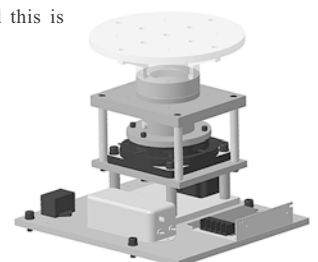

Power amplifier MAP202

MAP202 is a power amplifier of gain approximately 45dB and frequency range 30 to 1000MHz. The input damage level is +20dBm. MAP202 amplifies the signal from the signal generator and then supplies it to the broadband antenna. Moreover, the 1kHz square wave is output to the rear panel and connected to the signal generator for AM modulation of the signal. In addition, MAP202 is applied only to the anechoic box MY5310/5310S.



Signal generator

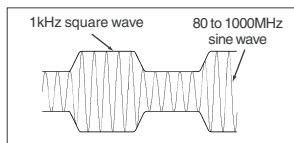

The signal of 80 to 1000MHz modulated by the 1kHz square wave (external input) or the sine wave is output. The modulation depth can be set up to 90%. The output level is programmed in this generator to compensate the amplitude characteristics of the power amplifier MAP202 and the broadband antenna MAN101, and to correspond to the electric field strength of 1 to 10V/m.

Anechoic box MY5310/5310S

The anechoic box is necessary not to leak the high power electromagnetic wave radiated by the antenna outside. MY5310/5310S uses the radio wave absorber of the ferrite tile which has the absorption efficiency of 20dB or more in the frequency range 80MHz to 2GHz. Therefore, the unnecessary reflection and resonance in the box are also suppressed.



Moreover, it has the turntable of 220mm in diameter and 10kg in load. The turntable can be turned with the rotary knob installed outside. The rotation angle can be accurately set by watching the rotation indicator. The electric turntable of 220mm in diameter and 15kg in load, which is a factory option, can be installed instead of this manual turntable. Besides, power supply inlet, D-sub connector, LAN connector and N type coaxial connectors are installed.

Broadband antenna MAN101

A transformational Y character monopole antenna (the original name by MICRONIX) with the frequency bandwidth 30MHz to 3GHz was developed by ourselves and greatly miniaturized. Furthermore, as for the distance of the antenna and the EUT, the transmission reference point of the antenna is the position of the signal pin of SMA connector where two antenna elements intersect.

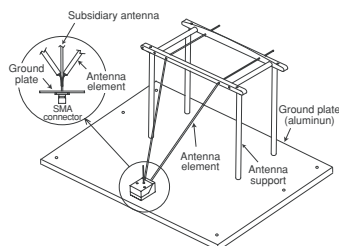

EUT camera monitor MEC235

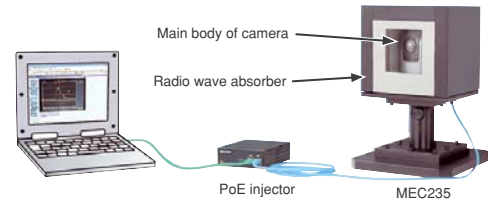

MEC235 is a camera to observe the malfunction of the EUT caused by the electromagnetic radiation. The EUT should be such an equipment as the malfunction can be visually judged. Because of being put in the anechoic box, the main body of camera is covered with the radio wave absorber (ferrite tile) and the pedestal is made of plastic. Therefore, the unnecessary reflection by the camera are suppressed. The camera can be zoomed up to 42 times, and the view range can be controlled within $\pm 29^\circ$ on the right and left, up to 23° upward and up to 35° downward.

This control can be done with the PC, and the image is displayed on the PC screen. The right picture is an example of the digital oscilloscope screen taken with MEC235. In addition, the power source of the camera is supplied through LAN cable from the PoE injector.

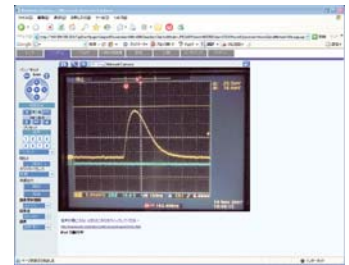

PC software MAS235

①.Sweep mode : FIX

This is a mode to output the electromagnetic wave of the fixed frequency. The setting frequency resolution is 1kHz. The ON/OFF control of RF OUT of the signal generator is also available.

②.Sweep mode : Sweep

The sweep frequency range is specified by the start frequency and the stop frequency. Either the frequency step or the ratio step can be selected as the step of sweep. The former means to sweep in each specified frequency step (1kHz to 100MHz), and the latter means to sweep in each specified ratio (0.1 to 20%). For instance, when assuming 10% step and the start frequency 80MHz, the frequency is swept like 80, 88, 96.8MHz... The time interval in each step is specified in the step time (0.1 to 20 sec). Furthermore, concerning the sweep, there are two modes of the single sweep at which the sweep is done only once and the repeat sweep.

The sweep begins by clicking START and finishes by clicking STOP. When clicking PAUSE, the electric field strength is kept generating in the frequency at that moment. Moreover, the frequency being swept currently is momentarily displayed in CURRENT FREQ text box.

③.Electric field strength

The electric field strength of 1, 3 or 10V/m should be basically set, but it's also available to set the optional value within 1 to 10V/m (1V/m resolution).

④.AM modulation

Basically, the modulation should be set to 1kHz square wave and 80% modulation depth. However, a sine wave besides a square wave can be selected as the modulation waveform, and the modulation depth can be optionally set within 0 to 90% (1% resolution). The modulation frequency is fixed to 1kHz.

① Sweep mode : FIX ③ Electric field strength

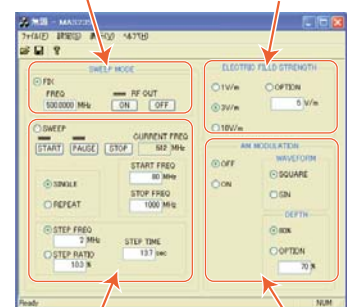

② Sweep mode : SWEEP ④ AM modulation

Specifications

System specifications

Test frequency range	80 to 1000MHz
Electric field strength	1, 3, 10V/m and option (1 to 10V/m, 1V/m resolution)
AM modulation	
Frequency	1kHz
Waveform	Square wave, Sine wave
Depth	80% and option (0 to 90%, 1% resolution)
ON/OFF	available
Sweep mode	
Frequency generation	Fix, Sweep
Resolution @ Fix	1kHz
Step of sweep	Frequency step : 1kHz to 100MHz, 1kHz resolution Ratio step : 0.1 to 20%, 0.1% resolution
Step time	0.1 to 20 sec, 0.1 sec resolution
Sweep method	Single, Repeat
EUT malfunction detection	By EUT camera monitor MEC235
Anechoic box supported	MY5310, MY5310S (without spacer unit)
Accessories	· N(P)/N(P) 1.5m coaxial cable (1 pc.) · N(P)/N(P) 1m coaxial cable (1 pc.) · BNC(P)/BNC(P) coaxial cable (1 pc.) · GP-IB interface board (1 pc.) · GP-IB cable (1 pc.) · Operating manual (1 pc.)

Power amplifier (MAP202)

Frequency range	30 to 1000MHz
Gain	46dB typ @ 30 to 600MHz 44.5dB typ @ 600 to 1000MHz
1dB compression level	42.5dBm typ @ 30 to 600MHz 41dBm typ @ 600 to 1000MHz
Input VSWR	less than 2.0
Output VSWR	less than 5.5
Maximum input level	+20dBm
Modulation output	
waveform	1kHz square wave
Amplitude	2Vp-p typ @ 50Ω
Output impedance	50Ω
Input/Output connectors	N (J) @ INPUT, OUTPUT BNC (J) @ AM SIG OUT
Power supply voltage	100 to 240VAC, 50 to 60Hz
Power consumption	approx. 80VA @ maximum output
Dimensions	430(W)×150(H)×440(D)mm (excluding projections)
Weight	approx. 10kg
Accessories	· Power cable (1 pc.) · Operating manual (1 pc.)

Anechoic box (MY5310/5310S)

Items	MY5310	MY5310S
Outside dimensions	1340(W)×1210(H)×1030(D)mm (excluding casters and projections)	1350(W)×1220(H)×1080(D)mm (excluding casters and projections)
Inside dimensions	1230(W)×920(H)×920(D)mm	
Door opening dimensions	410(W)×710(H)mm	510(W)×910(H)mm
Weight	approx. 460kg	
Turntable dimensions	220mmφ	
Turntable load	10kg	
Radio wave absorber	Ferrite tile structured double	
Coaxial	N (J) @ Antenna and EUT	
D-sub	25 pins	
LAN	one piece	
Power supply for EUT	AC250Vmax, three-pin plug	
Shielding efficiency	more than 65dB	
Absorption efficiency	more than 20dB @ 0.1 to 2GHz	
Accessories	Power cable (1 pc.), Coaxial cable for internal wiring (1 pc.), Operating manual (1 pc.)	

Broadband antenna (MAN101)

Frequency range	30MHz to 3GHz
Polarization	Linear
Impedance	50Ω (nominal)
Antenna type	Transformational Y character monopole antenna (original name by us)
Dimensions	Element : 578(W)×401(H)×250(D)mm Ground plate : 700(W)×900(D)mm
Weight	approx. 5.3kg (including ground plate)

EUT camera monitor (MEC235)

Image compression method	JPEG, MPEG-4
Resolution	640×480, 320×240, 192×144 dots
Zoom	42times/12stages (21times @ optical, twice @ digital)
Pan	±29°
Tilt	23° @ upward, 35° @ downward
Illuminance range	2 to 100,000 lx 0.09 to 100,000 lx @ color night view
Radio wave absorber	Ferrite tile and absorption seat ※ Pedestal is made of plastic.
Interface	LAN (100BASE-TX/10BASE-T)
Power supply	Supplied from PoE injector
Power consumption	approx. 5W @ waiting, approx. 9W @ pan scan
Dimensions	Camera part : 210(W)×190(H)×180(D)mm Pedestal : 230(W)×200(D)mm Total height : 342mm
Weight	approx. 5.7kg (including pedestal)
Accessories	· PoE injector and accessories (1 set) · LAN cable (3 pcs.) · Operating manual (1 pc.)

Signal generator

Frequency	
Frequency range	250kHz to 1GHz
Oscillator aging rate	≤ ± 5ppm/10yrs, < ± 1ppm/yr
Amplitude	
Output power range	-110 to +13dBm
Absolute level accuracy	≤ ± 0.6dB @ +7 to -60dBm ≤ ± 0.7dB @ < -60 to -110dBm
Amplitude modulation	
Waveform	Sine wave, External
Depth	90% max
Interface	GP-IB
Power supply voltage	100 to 120VAC, 220 to 240VAC, 50 to 60Hz
Power consumption	250W max
Dimensions	426(W)×87(H)×432(D)mm (excluding projections)
Weight	approx. 11kg
Accessories	1 set such as power cable

PC software (MAS235)

Recommended PC	More than Celeron/ 2GHz, Memory : more than 128MB, HD remainder capacity : more than 100MB, Communication port : LAN and GP-IB (PCMCIA slot)
Providing media	CD-ROM
OS	Windows 2000, XP, Vista
Web browser	Internet Explorer 6.0 or after (for MEC235)

Others

Operating temperature	0 to 40℃ (guaranteed at 23 ± 10℃)
Operating humidity	less than 40℃/80%RH (guaranteed at less than 33℃/70%RH)
Storage temperature	-20 to 60℃, less than 60℃/70%RH
Options	· Electric turntable (factory option) · PC software for electric turntable MAS20T, MAS240T

MICRONIX Corporation reserves the right to make changes in design, specifications and other information without prior notice.

MICRONIX
MICRONIX CORPORATION

2987-2, KOBIKI-CHO, HACHIOJI-SHI, TOKYO 193-0934 JAPAN

TEL. +81-42-637-3667 FAX. +81-42-637-0227

URL: <http://www.micronix-jp.com> E-mail: micronix_e@micronix-jp.com

AGENCY